

# Thompson Valve II<sup>®</sup>

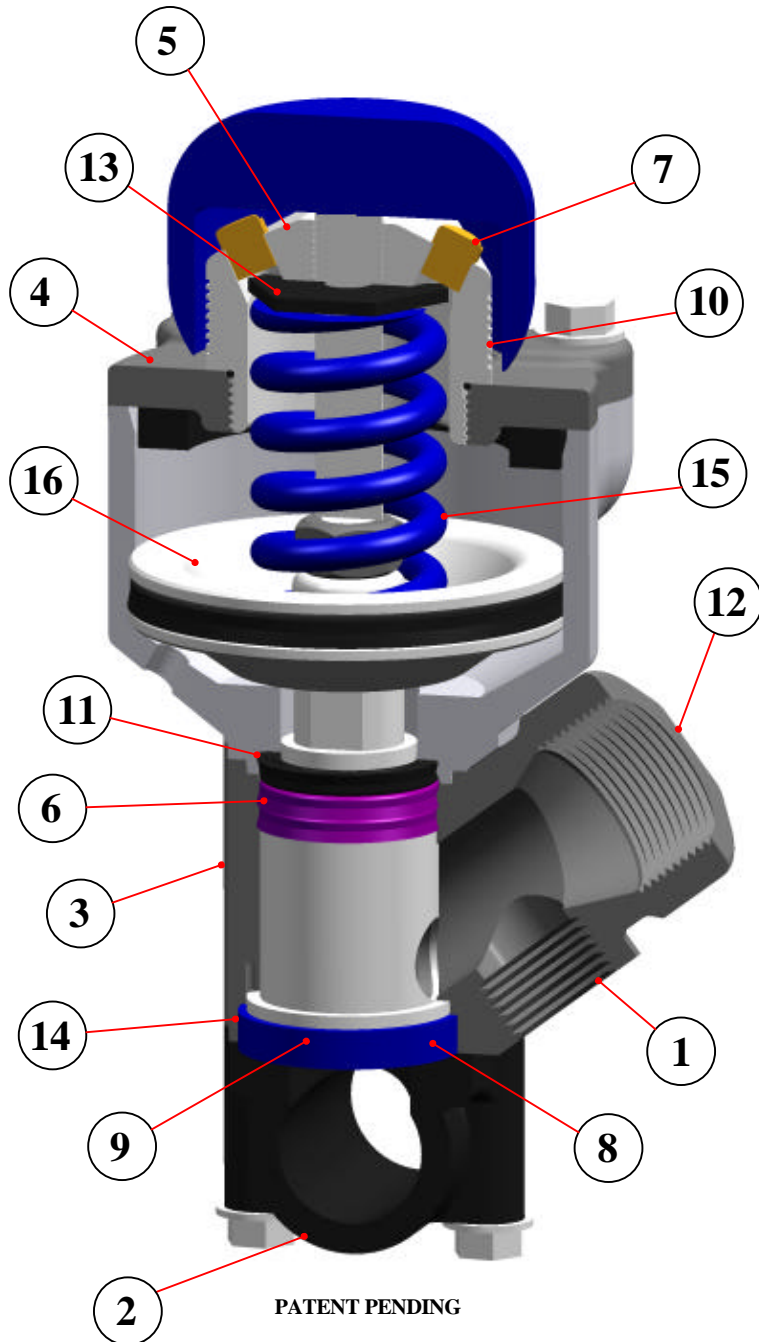

1. Clean-out placed directly under inlet provides easy removal of unwanted material.
2. Base and nipple integrated into one piece and constructed out of high strength hardened carbon steel eliminates the need for insert and o-ring.
3. Middle section made separate from cylinder to provide easier removal of sleeve, plunger seals, and seat during service.
4. Bolt on cap provides easier service to piston and piston seal.
5. Spring pre-loaded with spring retainer.
6. Triple plunger seals to prevent media from entering piston chamber, and to provide extended life to the valve.
7. Two fine micron breather vents in cap prevent dust from entering the piston chamber.
8. Larger seat allows for better media flow into the air stream.
9. Shallower angle on seat prevents media from being trapped under plunger, thus extending it's life.
10. Notches on spring retainer provides more precise and consistent metering capabilities.
11. Upper plunger seal can be installed upside down to allow for operation with different signal and blast pressures.
12. Flats on inlet ease in attaching valve to tank.
13. Anti-vibration disk now standard to prevent knob from backing out during use.
14. Seat placed in body allows for easier removal during servicing.
15. Spring re-designed to provide longer life.
16. Sloped piston allows unwanted dirt and moisture in the cylinder to drain away from critical areas and threads.

PATENT PENDING