

Multi-Media Series

Mid-size blaster with big capabilities!

Blast with both hard & soft abrasives

The M-21 is a mid-size blaster with a wide range of capabilities. From cleaning surface grease and oil to stripping rust or paint, the M-21 can achieve any surface profile. Its controls are so precise that it is able to remove paint from a light bulb.

The M-21 has a greater weight distribution for easier handling and an overall height of 43" which allows for easier filling. Our newly engineered chassis makes accessing the Thompson Valve® II a breeze.

Available Sizes: M-11, M-21, and M-31



Features and Benefits

- ⇒ Lower profile for easier filling
- ⇒ Greater weight distribution of controls and piping for easier handling
- ⇒ 150 psi 18" diameter vessel with 90° degree bottom cone
- ⇒ Integrated load skid and handle for loading and protection of controls and piping
- ⇒ Stainless steel control panel with differential pressure gauge for easier operation
- ⇒ Full by-pass piping for use of other blast media applications (available on M-21 & M-31)
- ⇒ Cyclonic moisture separator and air-regulator standard
- ⇒ Water attachment for dust suppression
- ⇒ Open chassis for greater access to Thompson Valve II
- ⇒ Thompson Valve II with Key-slotted (tungsten carbide sleeve) and clean out port
Other sleeve designs available
- ⇒ Pneumatic vibrator for increased flow of light media
- ⇒ Lid and screen standard

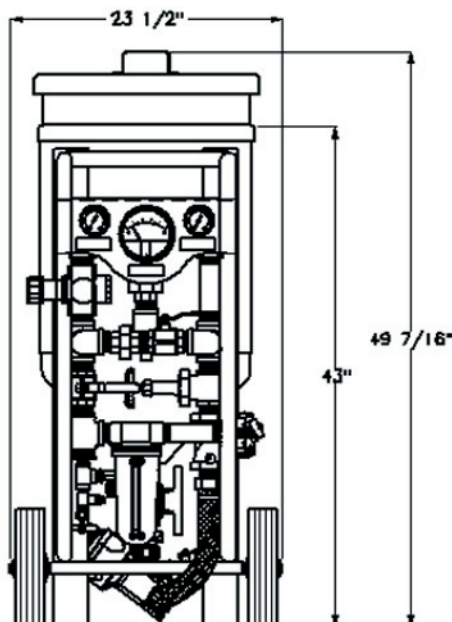

M-21

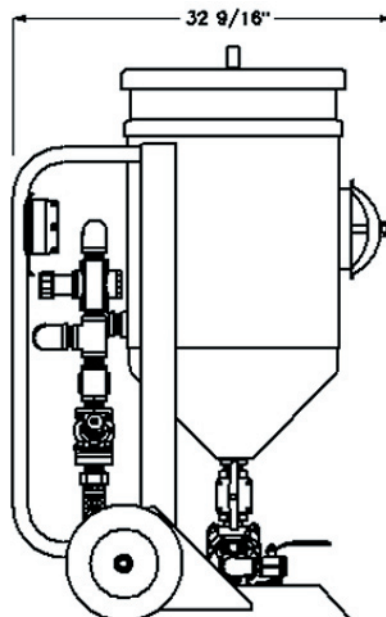

Multi Media Series

Portable M-Series® Multi Media Blaster, 150psi rated vessel with integrated load skid, media vibrator, ball valve w/sanitary clamp, lid and screen. Normally closed pneumatic remote controls including Thompson Valve® II with clean-out feature regulated piping with check valve (GSV), G2 Deadman® control with 55' twinline control hose and 55' water line with wet blast attachment. Blaster equipped with stainless steel panel and gauges. Gauge panel includes: Differential Blast, Tank pressure and Blast pressure (Blast hose and nozzle sold separately).

M-11 1.5 cu. ft. (42 liter), 1" piping, no bypass
(22" W x 33" L x 48" H)
(approx. shipping weight: 140 lbs.) (Part No. 8720-011)

M-21 2.0 cu. ft. (56 liter), 1 1/4" piping, with bypass
(24" W x 33" L x 50" H)
(approx. shipping weight: 160 lbs.) (Part No. 8720-021)

M-31 3.0 cu. ft. (85 liter), 1 1/4" piping, with bypass
(24" W x 33" L x 56" H)
(approx. shipping weight: 400 lbs.) (Part No. 8720-031)



INNOVATIVE ENGINEERING YOU RELY ON.

Schmidt Air Blast Equipment has led our industry for more than 30 years. You've come to trust Schmidt quality and the innovative engineering behind the name. Axxiom Manufacturing is now the force carrying on the Schmidt tradition, creating the quality products you rely on today, tomorrow and beyond. Look to us for the most productive, safe and reliable technology, from air blast equipment and components to engineered abrasive systems.

THE NAME YOU TRUST.



Visit www.AxxiomMfg.com
for more on
Schmidt Airblast Equipment

Axxiom Manufacturing, Inc.
11927 South Highway 6
Fresno, TX 77545
1.800.231.2085



© 2009 Axxiom Manufacturing Co., Inc.

Axxiom Manufacturing, Inc. is the exclusive manufacturer of Schmidt® products. Certain products manufactured by Axxiom Manufacturing Inc are protected by patents pending in the United States and other countries. MV is a trademark and Schmidt, the stylized "S", Axxiom, Combovalve, Microvalve, MV2 and Thompson Valve are registered trademarks of Axxiom Manufacturing, Inc. All rights reserved.